



Family Learning

Practical Woodworking

National 5



Course Update

Including a question paper will allow more skills, knowledge and understanding to be sampled following the removal of units and unit assessments from the course.

These changes were implemented in 2017/18

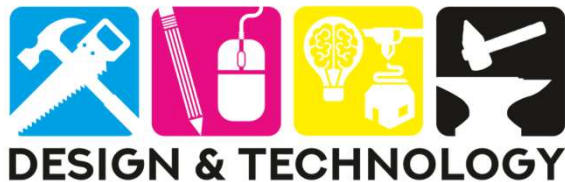

Assessment Arrangements

Assessment	Total Marks	Value	Marking
Assignment	70	70%	Internal
Question paper	60	30%	External

Question paper time 1 Hour

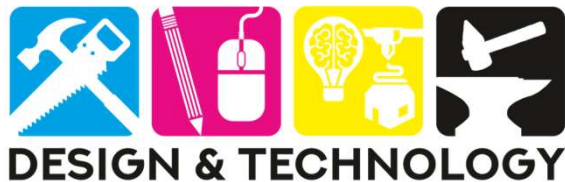

Course Timeline

- Oct/ Nov 2018 – Supported Study
 - Dec 2018 – Prelim (Date TBC)
- Late 2018 – Assignment published by SQA
- Late 2018/Early 2019 – Pupils complete Assignment
- Feb / Mar/ Apr – Supported Study Sessions (exact number TBC)
- May 2019 – SQA Exam (03/05/2019)

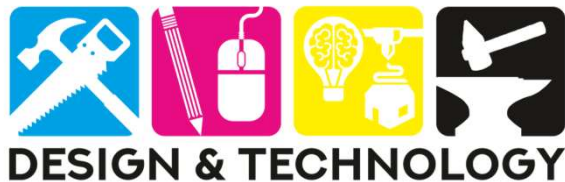

14:00-15:00

Assignment

The assignment will be published by the SQA in late 2018

The assignment will assess the skills and knowledge the pupils have acquired during the course. The assignment covers three key areas:

- **Flate frame construction**
- **Carcasse construction**
- **Machining and finishing**

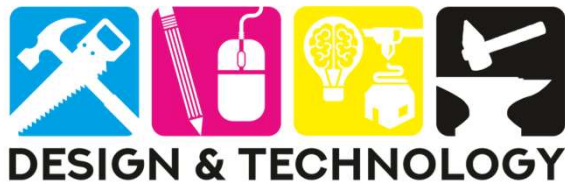

Assignment

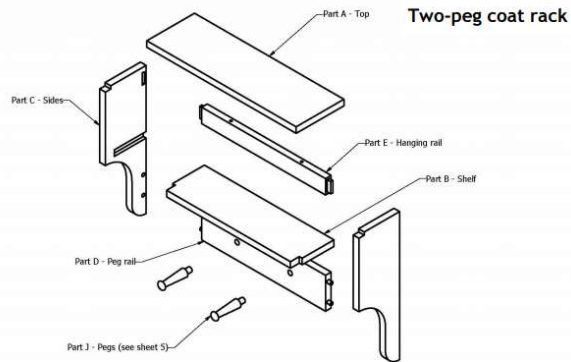

EXPLODED ISOMETRIC (CARCASE)

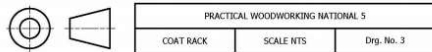

Version 1.0



Two-peg coat rack

Part	No.	Material	Length	Breadth	Thickness
A	1			35	
B	1			35	
C	2			35	
D	1			35	
E	1			35	

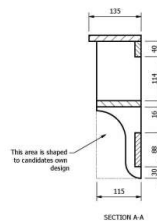
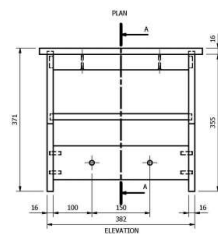

Version 1.0

24

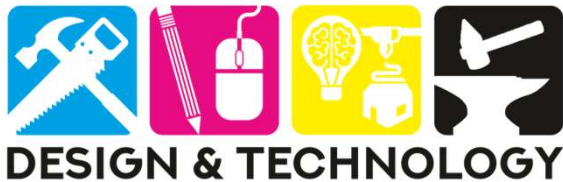

Independence of work (up to 3 marks)

For guidance on reasonable assistance, assessors must refer to the 'Instructions for teachers and lecturers' section.

In general, additional assistance would likely be where assessors have to demonstrate or describe a procedure.

All finishing work has been carried out independently, with no additional assistance required	3
Finishing work has been carried out independently, with one or two instances of assistance required	2
Finishing work has been carried out, with regular assistance required	1
Finishing work has been carried out, with constant assistance required	0
Total marks available	10 marks

Coat rack (two-peg and four-peg)

You may demonstrate practical creativity in shaping both the turned parts and/or the sides of the coat rack, however, this is not mandatory.

You must include templates and working drawings of the turned pegs and shaping of the sides of coat rack with your work. These are used to help your assessor make their assessment decisions.

You must complete the log book, as this attracts specific marks.

The following tolerances apply to this practical activity:

Operation	Tolerance
Individual components	
Planing (or similar)	±1mm
Marking out and cutting	±1mm
Machine/power tool tasks:	
♦ vertical drilling ♦ sanding to a line ♦ drilling to a given line position	±1mm
Joint gaps	not to exceed 1mm
Overall sizes	±3mm

Assignment (log book)

Machine and power tool care and maintenance

Procedure and date carried out	Before using, I checked...	After using, I checked...	Candidate signature	Assessor signature	1 mark or 0 marks and comments
<p>Procedure 1 Using the pedestal drill to drill clearance holes for screws.</p> <p>23rd October 2017</p>	<p>All the guards were in place. The table was secure. The work piece was secured. The switches were not damaged.</p> <p>I noticed a guard was loose and reported it to my teacher.</p>	<p>The power was off at the isolator. The drill was removed from chuck. The chuck key removed and stored. The machine was cleaned.</p>	A. Candidate	AN. Assessor	<p>1 mark 1 mark awarded, as the candidate has given 4 or 5 pre-use checks, has indicated a fault and what action they took. The candidate has indicated 4 or 5 post-use checks.</p>
<p>Procedure 2 Cutting out shape with the jig saw.</p> <p>15th November 2017</p>	<p>I had permission to use the jig saw. The plug and cable on the jig saw were ok. The saw blade was secure. The work piece was held securely. The dust extractor was in place and not clogged up.</p>	<p>The jig saw was unplugged. The the plug and cable were ok. There was no damage to the blade. I cleaned all the sawdust from the jig saw and put it away safely.</p>	A. Candidate	AN. Assessor	<p>1 mark 1 mark awarded, as the candidate has given 4 or 5 pre-use checks. The candidate has indicated 4 or 5 post-use checks.</p>
<p>Procedure 3 Setting up blank between centres on lathe for turning coat hooks.</p> <p>11th January 2018</p>	<p>The wood was ok.</p>	<p>Everything was ok.</p>	A. Candidate	AN. Assessor	<p>0 marks Zero marks awarded, as the candidate has not specified any pre-use checks or procedures carried out for setting up the blank. No post-use checks are listed.</p>

Assignment pitfalls

- Time management
- Log book not being completed properly
 - Pupils rushing key areas (finishing)
 - No teacher input or help
- Pupils not planning time effectively and missing out large parts of tasks.

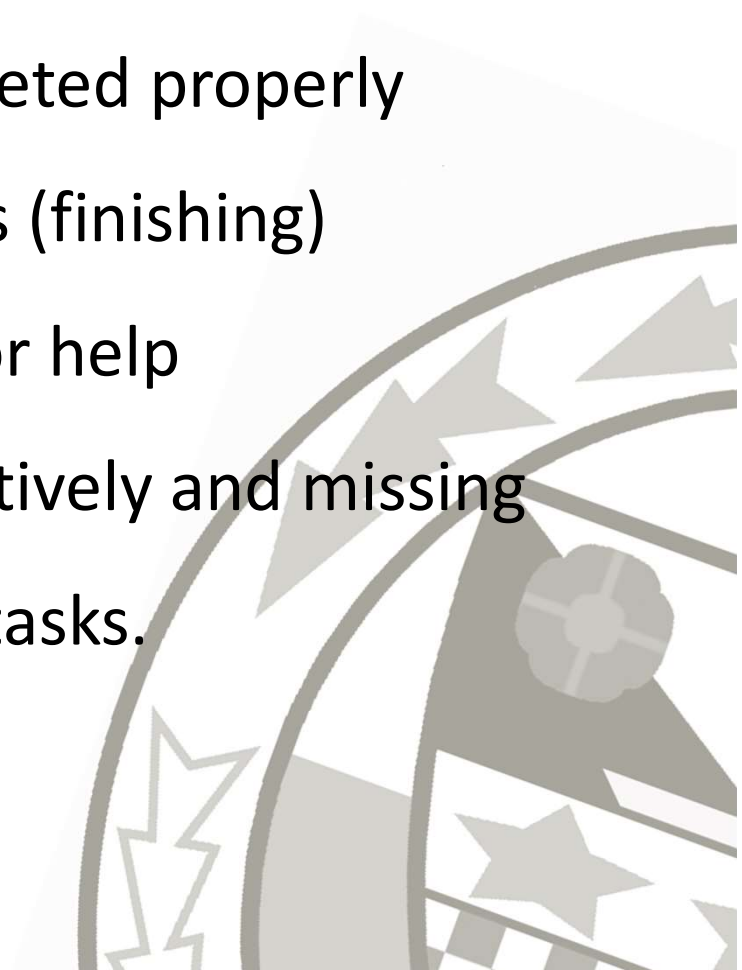
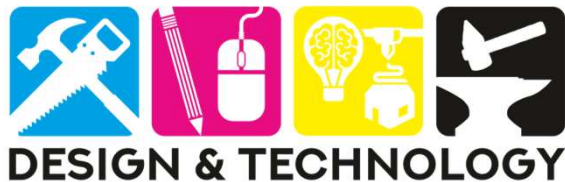

Question Paper

2. (continued)

This diagram shows the four feet of the shelving unit being turned on the woodwork lathe.

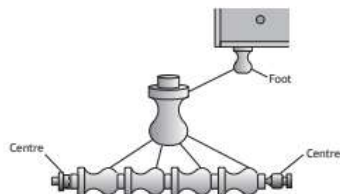

All four feet are made from one piece of hardwood, called a 'wooden blank', as shown in the diagram below.

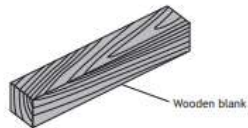

The wooden blank is prepared for the turning process before it is mounted on the woodwork lathe.

There are five stages in the preparation of the wooden blank before fitting it between the centres on the lathe. The first stage is to draw diagonals on the ends of the wooden blank.



page 10

MARKS

2. (continued)

(e) Describe the next four stages in the correct order. You may use sketches to support your answer.

4

Stage 2
Stage 3
Stage 4
Stage 5

[Turn over



page 11

Question paper pitfalls

- Not writing enough detail

(Especially with Sequence of operations Questions, assume marker knows nothing)

- Pupils not taking note of key words or indicators
- Pupils not taking note of allocated marks per question

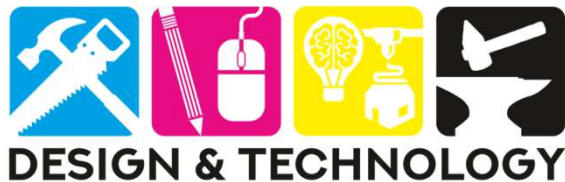

Preparation and Support

- Encourage supported study or lunch time drop in
- Encourage pupils to check GLOW regularly for uploads / announcements
- Ask pupils if they have any homework, course work or deadlines due
- Bright Red Course Notes

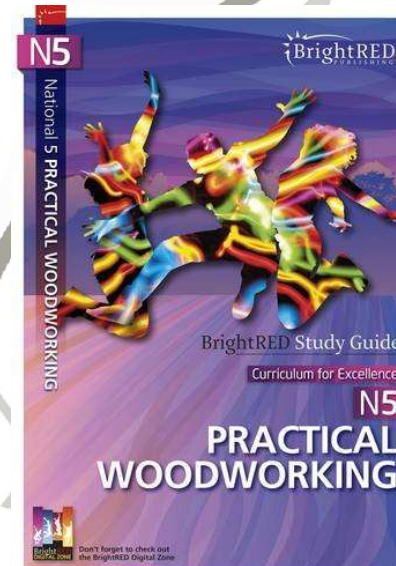
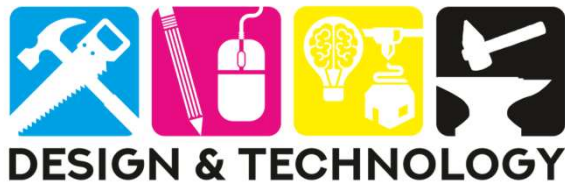

GLOW

Revision material will be uploaded to Microsoft Teams as well as handing out physical copies meaning resources can be accessed anywhere, anytime.

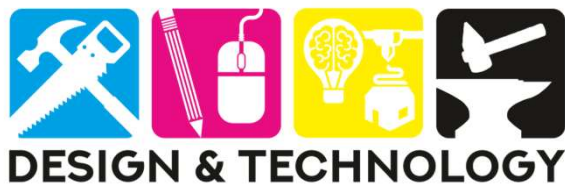
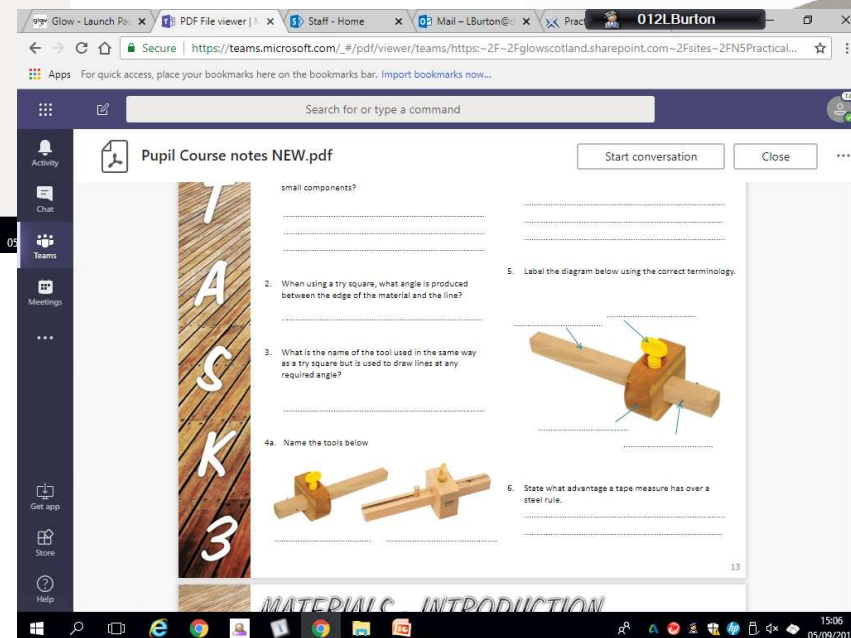
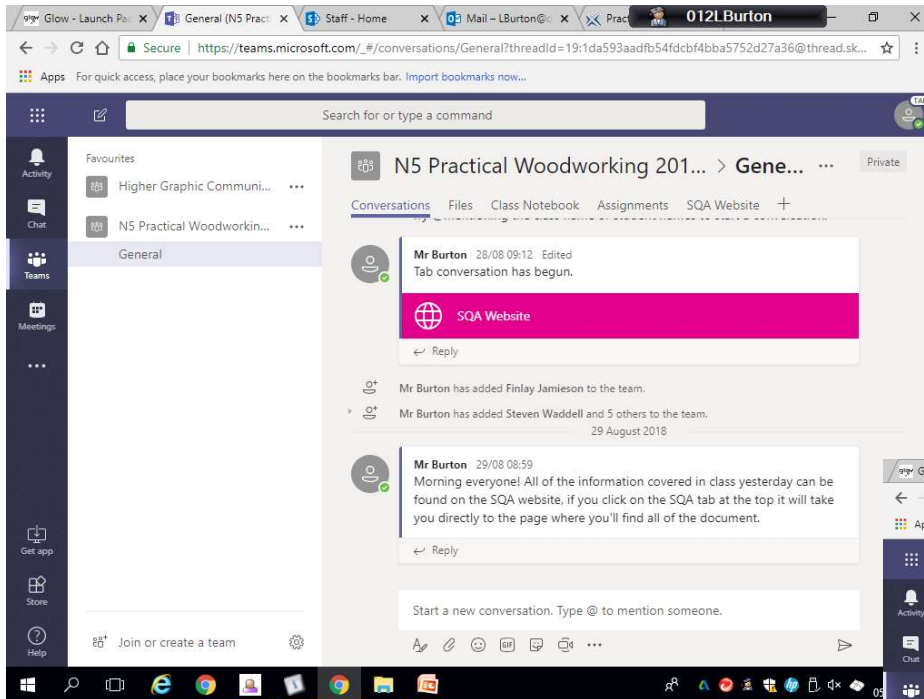

Resources

SQA Website –

<https://www.sqa.org.uk/sqa/47462.html>

